

Ecoflam



**HEATING UNITS
MADE OF STEEL**
high-efficiency

Ecomax N
Duomax N
Duomax PN



Ecomax N

70 ÷ 350



**REVERSE FLAME STEEL
BOILER COMPLETE
WITH MATCHED BURNER**



Internal view of combustion chamber



Special high-efficiency steel turbulator

Control panel:

STANDARD VERSION:

For models with 1/2 flame settings.

ELECTRONIC VERSION:

Variable temperature operation, controlling one mixed circuit (mixer valve + pump) management of cascading generators (max 16 power stages).

Available also in versions:

ECOMAX NC (boiler only)

ECOMAX NCS (dismantled boiler only)

Ecomax N natural gas features:

Rated supply pressure: 20 mbar;
gas ramps available with rated pressures 40, 100,
300 mbar. For other supply pressures only on
request.

Ecomax N boilers are designed to ensure the utmost: power efficiency, quietness, safety and durability. The Ecomax N range provides a new generation of heating boilers (with the possibility of variable temperature operation) that are particularly compact. The boiler is able to resolve any problem related to the new installation or when replacing existing appliances in old heating plants that are small in size and have awkward access. The reliability of the Ecomax N boiler stems from the perfect matching of the boiler shell and burner chosen at the design stage.

Heating packaged boiler:

Mechanical: burners and accessories already included;

Heating: choice of burner and pre-setting according to the power and boiler operation methods;

Electrical: boiler and burner prewired together.

Features:

- Gas or diesel heating operation;
- Complete with forced draught burner;
- Boiler and burner perfectly integrated for power and operation in total safety;
- Very thick steel shell;
- Pressurized furnace with flame reversal;
- Cylindrical flue pipes equipped with special turbulators;
- Complete with control panel (depending on type of operation);
- Prewired control panel and burner;
- High thermal insulation;
- Stylish casing;
- High seasonal efficiency (heating unit in conformity with Italian law 10 dated 9/1/91 and Italian Presidential Decree D.P.R. no.412 dated 26/8/93).

When there are special needs to lower the noise levels in the heating plant, an additional silencer is available on request, to be fitted to the burner intake.

ECOMAX N 70 ÷ 350

		70 (2)	80 (2)	90 (2)	100 (2)	120	150	200	250	300	350	
Thermal power	max	kcal/h	60.200	68.800	77.400	86.000	103.200	129.000	172.000	215.000	258.000	301.000
		kW	70	80	90	100	120	150	200	250	300	350
	min	kcal/h	30100	34400	38700	43000	51600	64500	86000	107500	129000	150500
		kW	35	40	45	50	60	75	100	125	150	175
Thermal capacity	max	kcal/h	65.580	74.950	84.310	93.680	112.420	140.520	187.360	234.200	279.520	326.110
		kW	76,3	87,1	98	108,9	130,7	163,4	217,9	272,3	325	379,2
	min	kcal/h	32.790	37.475	42.155	46.840	56.210	70.260	93.680	117.100	139.760	163.055
		kW	38,1	43,6	49	54,5	65,4	81,7	108,9	136,2	162,5	189,6
Nitrogen oxide emissions		ppm	< 55	< 55	< 55	< 55	< 55	< 55	< 55	< 55	< 55	
NOx (0% O ₂) for natural gas		mg/kWh	< 97	< 97	< 97	< 97	< 97	< 97	< 97	< 97	< 97	
Nitrogen oxide emissions		ppm	< 100	< 100	< 100	< 100	< 100	< 100	< 100	< 100	< 100	
NOx (0% O ₂) for diesel		mg/kWh	< 180	< 180	< 180	< 180	< 180	< 180	< 180	< 180	< 180	
Boiler max operating pressure		bar	6	6	6	6	6	6	6	6	6	
Max electric input	Diesel	kW	0,1	0,1	0,13	0,13	0,13	0,25	0,37	0,55	0,55	
	Gas	kW	0,075	0,075	0,075	0,25	0,25	0,3	0,3	0,3	0,55	
Capacity		l	105	105	123	123	123	172	172	220	300	356
Losses of head on water side (1)		mbar	9	10	11	12	13	14	15	16	16	18
Combustion chamber backpressure		mbar	0,8	1	0,8	1	1,1	1,2	1,9	2	2	2,9
Weight		kg	200	200	240	240	240	320	320	400	440	500

Overall dimensions		70 (2)	80 (2)	90 (2)	100 (2)	120	150	200	250	300	350
Dimensions mm	A	700	700	700	700	700	750	750	750	850	850
	A1	750	750	750	750	750	800	800	800	900	900
	B	630	630	755	755	755	1000	1000	1250	1250	1500
	B1	895	895	1020	1020	1020	1267	1267	1517	1517	1769
	C	1000	1000	1120	1120	1120	1365	1365	1615	1615	1865
	D	415	415	415	415	415	440	440	440	490	490
	E	415	415	415	415	415	440	440	440	490	490
	H	855	855	855	855	855	905	905	905	1005	1005
	L	240	240	265	265	265	475	475	725	700	980
	M	415	415	484	484	484	484	484	484	484	484
	P	56	56	56	56	56	56	56	56	56	56
	Q (3)	204	204	204	204	280	280	280	390	555	555
	∅c	200	200	200	200	200	250	250	250	250	250
Couplers ND / in	N1/N2	50	50	50	50	50	50	50	50	65	65
	N3	1"	1"	1"	1"	1"	1"	1"	1"	1"	1"
	N4	1"	1"	1"	1"	1"	1"	1"	1"	1"	1"
	N5	(4)	(4)	(4)	(4)	(4)	(4)	(4)	(4)	(4)	(4)
	N6	1/2"	1/2"	1/2"	1/2"	1/2"	1/2"	1/2"	1/2"	1/2"	1/2"

Contd...

- (1) Head losses referring to a temperature jump of 12°C;
- (2) Boiler exempt from fire prevention control;
- (3) For gas burners, the depth Q does not include the gas ramp (this distance refers to ECOFLAM burners only);
- (4) Coupler not included

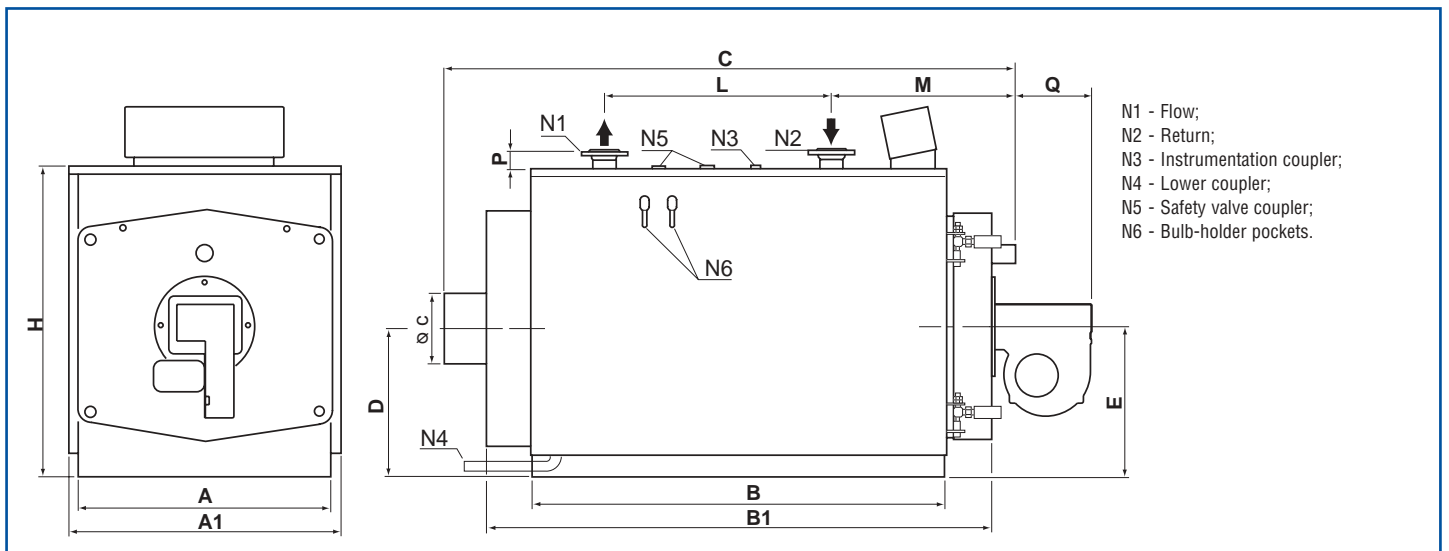

Ecomax N

420 ÷ 1300



**REVERSE FLAME STEEL
BOILER COMPLETE
WITH MATCHED BURNER**

Ecomax N boilers are designed to ensure the utmost: power efficiency, quietness, safety and durability. The Ecomax N range provides a new generation of heating boilers (with the possibility of variable temperature operation) that are particularly compact. The boiler is able to resolve any problem related to the new installation or when replacing existing appliances in old heating plants that are small in size and have awkward access. The reliability of the Ecomax N boiler stems from the perfect matching of the boiler shell and burner chosen at the design stage.

Heating packaged boiler:

Mechanical: burners and accessories already included;

Heating: choice of burner and pre-setting according to the power and boiler operation methods;

Electrical: boiler and burner prewired together.

Features:

- Gas or diesel heating operation;
- Complete with forced draught burner;
- Boiler and burner perfectly integrated for power and operation in total safety;
- Very thick steel shell;
- Pressurized furnace with flame reversal;
- Cylindrical flue pipes equipped with special turbulators;
- Complete with control panel (depending on type of operation);
- Prewired control panel and burner;
- High thermal insulation;
- Stylish casing;
- High seasonal efficiency (heating unit in conformity with Italian law 10 dated 9/1/91 and Italian Presidential Decree D.P.R. no.412 dated 26/8/93).

When there are special needs to lower the noise levels in the heating plant, an additional silencer is available on request, to be fitted to the burner intake.



High-density glass wool thermal insulation, 80 mm thick.

Control panel:

STANDARD VERSION:

For models with 1/2 flame settings.

ELECTRONIC VERSION:

Variable temperature operation, controlling one mixed circuit (mixer valve + pump) management of cascading generators (max 16 power stages).

Available also in versions:

ECOMAX NC (boiler only);

ECOMAX NCS (dismantled boiler only).

Ecomax N natural gas features:

Rated supply pressure: 20 mbar;
gas ramps available with rated pressures 40, 100, 300 mbar. For other supply pressures only on request.

ECOMAX N 420 ÷ 1300

			420	510	630	750	870	970	1030	1200	1300
Thermal power	max	kcal/h	361.200	438.600	541.800	645.000	748.200	834.200	885.800	1.032.000	1.118.000
		kW	420	510	630	750	870	970	1.030	1.200	1.300
	min	kcal/h	180.600	219.300	270.900	322.500	374.100	417.100	442.900	516.000	559.000
		kW	210	255	315	375	435	485	515	600	650
Thermal capacity	max	kcal/h	391.330	475.190	587.000	698.810	810.620	903.790	959.700	1.118.090	1.211.270
		kW	455	552,5	682,6	812,6	942,6	1.050,90	1115,9	1300,1	1408,5
	min	kcal/h	195.665	237.595	293.500	349.405	405.310	451.895	479.850	559.045	605.635
		kW	227,5	276,3	341,3	406,3	471,3	525,5	558	650,1	704,2
Nitrogen oxide emissions		ppm	< 55	< 55	< 55	< 55	< 55	< 55	< 55	< 55	< 55
NOx (0% O ₂) for natural gas		mg/kWh	< 97	< 97	< 97	< 97	< 97	< 97	< 97	< 97	< 97
Nitrogen oxide emissions		ppm	< 100	< 100	< 100	< 100	< 100	< 100	< 100	< 100	< 100
NOx (0% O ₂) for diesel		mg/kWh	< 180	< 180	< 180	< 180	< 180	< 180	< 180	< 180	< 180
Boiler max operating pressure		bar	6	6	6	6	6	6	6	6	6
Max electric input	Diesel	kW	0,74	0,74	1,1	1,1	2,2	2,2	2,2	3	3
	Gas	kW	0,55	0,74	1,1	1,1	2,2	2,2	2,2	3	3
Capacity		l	360	540	645	855	855	950	1200	1200	1200
Losses of head on water side (1)		mbar	25	22	27	25	25	39	26	30	30
Combustion chamber backpressure		mbar	4,1	4,2	6,4	5,2	7,2	5,2	4	5,5	6,5
Weight		kg	540	800	900	1140	1140	1340	1760	1760	1760

Overall dimensions		420	510	630	750	870	970	1030	1200	1300
Dimensions mm	A	890	1110	1110	1240	1240	1240	1390	1390	1390
	A1	940	1160	1160	1290	1290	1290	1440	1440	1440
	B	1502	1502	1792	1753	1753	2003	2003	2003	2003
	B1	1791	1838	2127	2143	2143	2393	2374	2374	2374
	C	1875	1950	2240	2250	2250	2500	2500	2500	2500
	D	500	610	610	675	675	675	750	750	750
	E	500	610	610	675	675	675	750	750	750
	H	1015	1205	1205	1335	1335	1335	1485	1485	1485
	L	850	850	1150	1100	1100	1200	1200	1200	1200
	M	600	660	660	710	710	710	710	710	710
	P	80	80	80	82	82	82	83	83	83
	Q (3)	555	555	555	555	555	555	555	660	660
	øc	250	300	300	350	350	350	400	400	400
Couplers ND / in	N1/N2	80	80	80	100	100	100	125	125	125
	N3	1"	1"	1"	1"	1"	1"	1"	1"	1"
	N4	1"	1" 1/4	1" 1/4	1" 1/4	1" 1/4	1" 1/4	1" 1/4	1" 1/4	1" 1/4
	N5	1" 1/4 (2)	1" 1/4	1" 1/4	1" 1/2	1" 1/2	1" 1/2	1" 1/2	1" 1/2	1" 1/2
	N6	1/2"	1/2"	1/2"	1/2"	1/2"	1/2"	1/2"	1/2"	1/2"

(1) Head losses referring to a temperature jump of 12°C;

(2) Boiler exempt from fire prevention control;

(3) For gas burners, the depth Q does not include the gas ramp (this distance refers to ECOFLAM burners only)

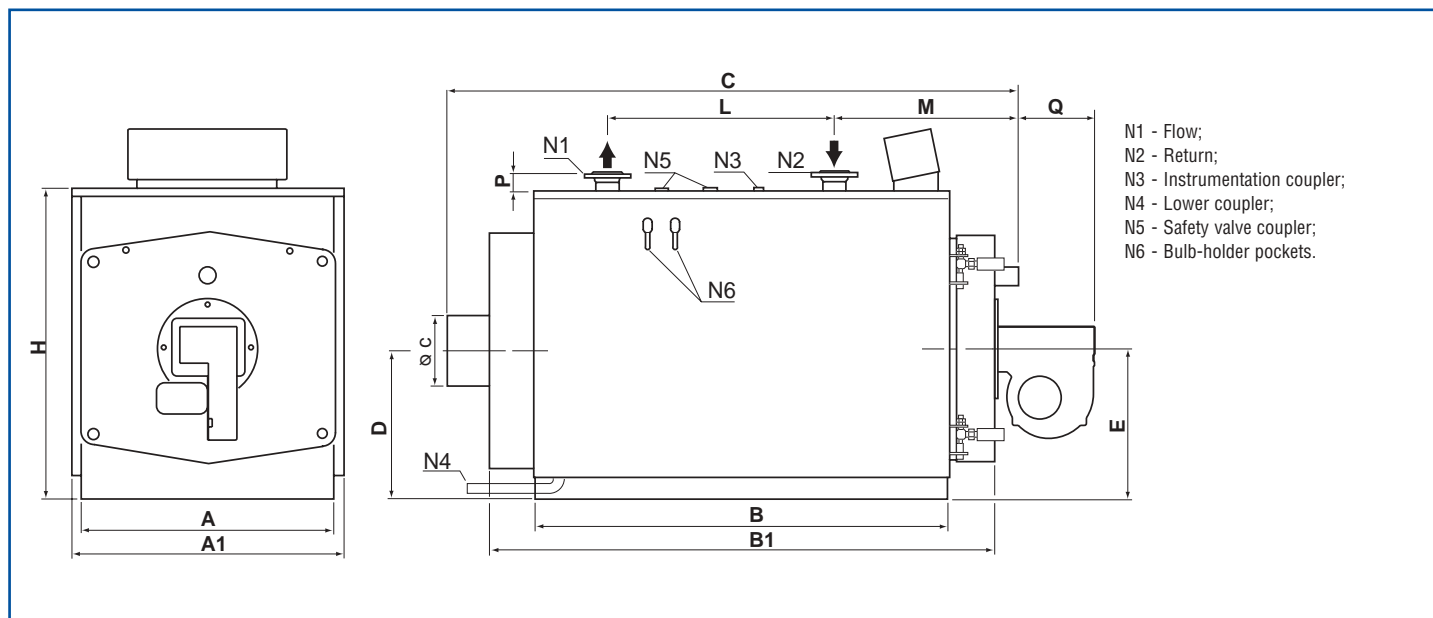

Ecomax N

1400 ÷ 3500

**REVERSE FLAME STEEL
BOILER COMPLETE
WITH MATCHED BURNER**

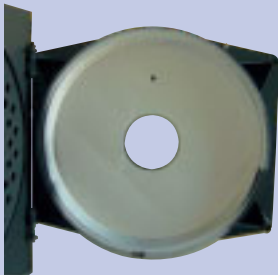

Internal door lined with ceramic fibre for high insulation

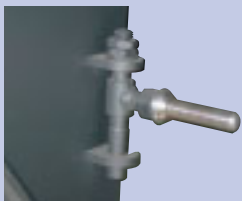

Special closing: for better maintenance the door can be opened either to the right or to the left.

Control panel:

STANDARD VERSION:

For models with 1/2 flame settings.

ELECTRONIC VERSION:

Variable temperature operation, controlling one mixed circuit (mixer valve + pump) management of cascading generators (max 16 power stages).

Available also in versions:

ECOMAX NC (boiler only)

ECOMAX NCS (dismantled boiler only)

Ecomax N natural gas features:

Rated supply pressure: 20 mbar;
gas ramps available with rated pressures 40, 100, 300 mbar. For other supply pressures only on request.

Ecomax N boilers are designed to ensure the utmost: power efficiency, quietness, safety and durability. The Ecomax N range provides a new generation of heating boilers (with the possibility of variable temperature operation) that are particularly compact. The boiler is able to resolve any problem related to the new installation or when replacing existing appliances in old heating plants that are small in size and have awkward access. The reliability of the Ecomax N boiler stems from the perfect matching of the boiler shell and burner chosen at the design stage.

Heating packaged boiler:

Mechanical: burners and accessories already included;

Heating: choice of burner and pre-setting according to the power and boiler operation methods;

Electrical: boiler and burner prewired together.

Features:

- Gas or diesel heating operation;
- Complete with forced draught burner;
- Boiler and burner perfectly integrated for power and operation in total safety;
- Very thick steel shell;
- Pressurized furnace with flame reversal;
- Cylindrical flue pipes equipped with special turbulators;
- Complete with control panel (depending on type of operation);
- Prewired control panel and burner;
- High thermal insulation;
- Stylish casing;
- High seasonal efficiency (heating unit in conformity with Italian law 10 dated 9/1/91 and Italian Presidential Decree D.P.R. no.412 dated 26/8/93).

When there are special needs to lower the noise levels in the heating plant, an additional silencer is available on request, to be fitted to the burner intake.

ECOMAX N 1400 ÷ 3500

			1400	1600	1800	2000	2400	3000	3500
Thermal power	max	kcal/h	1.204.000	1.376.000	1.548.000	1.720.000	2.064.000	2.580.000	3.010.000
		kW	1400	1600	1800	2000	2400	3000	3500
	min	kcal/h	602000	688000	774000	860000	1032000	1290000	1505000
		kW	700	800	900	1000	1200	1500	1750
Thermal capacity	max	kcal/h	1.304.440	1.490.790	1.677.140	1.863.490	2.236.190	2.795.230	3.261.110
		kW	1516,8	1733,5	1950,2	2166,8	2600,2	3250,3	3792
	min	kcal/h	652.220	745.395	838.570	931.745	1.118.095	1.397.615	1.630.555
		kW	758,4	866,7	975,1	1083,4	1300,1	1625,1	1896
Nitrogen oxide emissions		ppm	< 55	< 55	< 55	< 55	< 55	< 55	< 55
NOx (0% O ₂) for natural gas		mg/kWh	< 97	< 97	< 97	< 97	< 97	< 97	< 97
Nitrogen oxide emissions		ppm	< 100	< 100	< 100	< 100	< 100	< 100	< 100
NOx (0% O ₂) for diesel		mg/kWh	< 180	< 180	< 180	< 180	< 180	< 180	< 180
Boiler max operating pressure		bar	6	6	6	6	6	6	6
Max electric input	Diesel	kW	3	4	4	7,5	7,5	9	11
	Gas	kW	3	4	4	5,5	5,5	7,5	11
Capacity		l	1500	1500	1650	2000	2300	3150	3650
Losses of head on water side (1)		mbar	28	32	37	35	40	49	60
Combustion chamber backpressure		mbar	6	6,5	5,5	6	7,5	8	8,5
Weight		kg	2600	2600	2750	3650	3900	5200	5700

Overall dimensions		1400	1600	1800	2000	2400	3000	3500
Dimensions mm	A	1270	1270	1270	1400	1400	1670	1670
	A1	1470	1470	1470	1600	1600	1870	1870
	B	2300	2300	2510	2510	2770	2770	3225
	B1	2793	2793	3003	3132	3392	3392	3847
	C	2850	2850	3060	3190	3450	3450	3900
	D	880	880	880	945	945	1080	1080
	E	880	880	880	945	945	1080	1080
	H	1630	1630	1630	1760	1760	2030	2030
	L	1300	1300	1850	1550	1950	2050	2050
	M	795	795	735	870	870	870	870
	P	116	116	116	116	116	116	116
	Q (2)	660	660	660	810	810	810	810
	øc	400	400	400	500	500	550	550
	Couplers ND / in	N1/N2	150	150	150	200	200	200
N3		1"	1"	1"	1"1/2	1"1/2	1"1/2	1"1/2
N4		1"1/4	1"1/4	1"1/4	1"1/4	1"1/4	1"1/4	1"1/4
N5		1"1/2	1"1/2	1"1/2	2"	2"	2"	2"
N6		(3)	(3)	(3)	(3)	(3)	(3)	(3)

(1) Head losses referring to a temperature jump of 12°C;

(2) For gas burners, the depth Q does not include the gas ramp (this distance refers to ECOFLAM burners only);

(3) Coupler not included

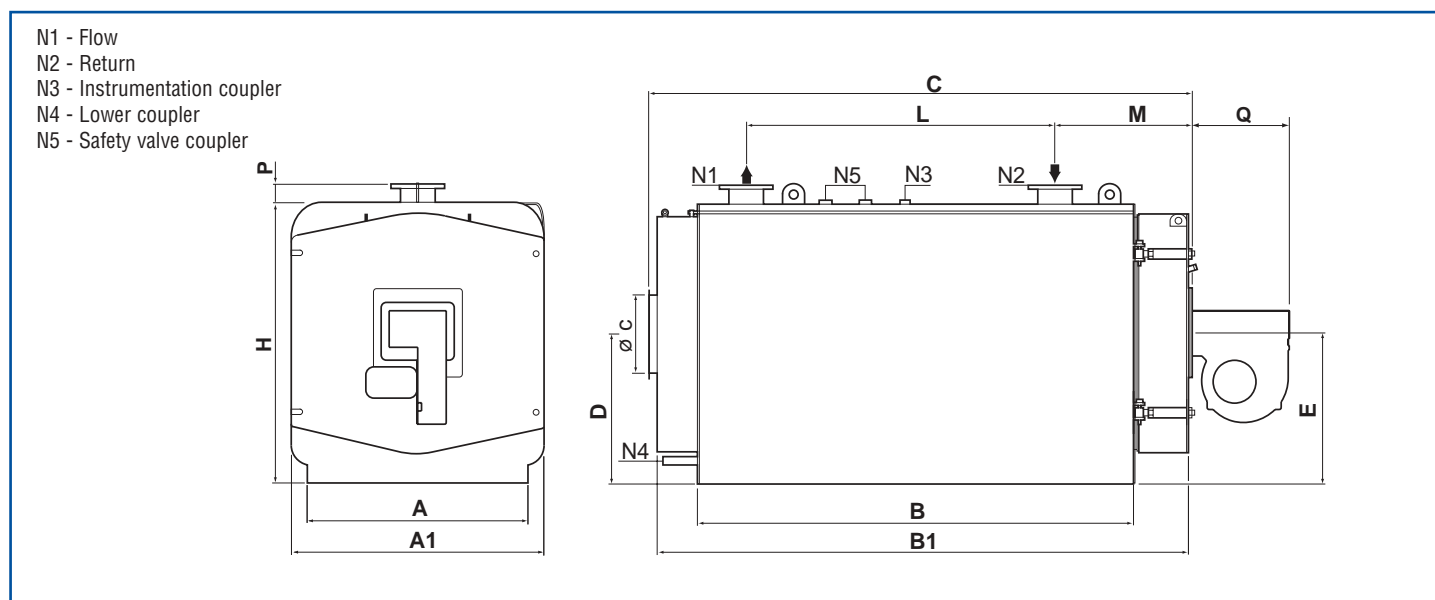

Ecomax N Control Panel

STANDARD CONFIGURATION FOR ECOMAX N WITH 1 OR 2 FLAME SETTINGS

- Control thermostat;
- Second stage thermostat;
- Minimum thermostat;
- Safety thermostat;
- Thermometer;
- Burner switch;
- Circulator switch;
- Illuminated main switch.

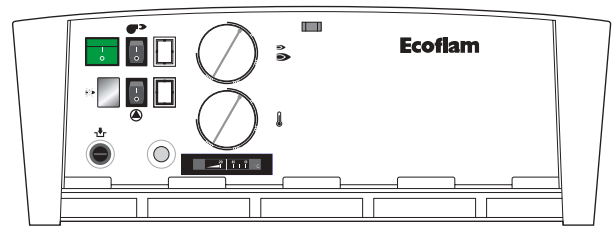

FOR ECOMAX N 70 - 3500

ADDITIONAL FUNCTIONS FOR ELECTRONIC VERSION

- Heating timer programming;
- DHWS timer programming;
- Battery reserve: 2 years;
- Burner power management;
- Temperature curve setting compensated by external sensor;
- Heating unit circulator control;
- Control of a heating zone with a pump and possibly a mixer valve (an additional sensor is necessary);
- Tap water circulator control;
- Possibility of BMS control with 0-10V control;
- Possibility of MASTER or SLAVE configuration for cascade operation (up to a maximum of 16 power stages), with additional sensor;
- Possibility of a remote control connection;
- Complete with external sensor.

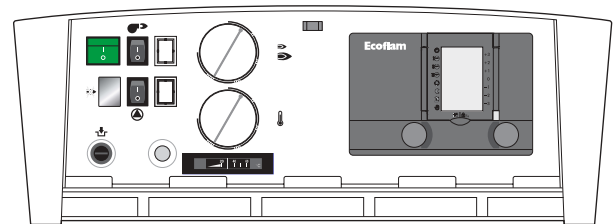

FOR ECOMAX N 70 - 3500

Ecomax NC, Ecomax NCS Control Panel

CONFIGURATION WITH 1 OR 2 FLAME SETTINGS

- Control thermostat;
- Second stage thermostat;
- Minimum thermostat;
- Safety thermostat;
- Thermometer;
- Burner switch;
- Circulator switch.

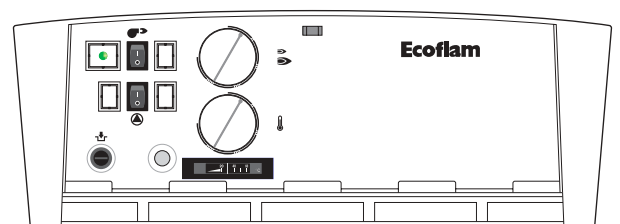

FOR ECOMAX NC 70 - 3500

Duomax N, Duomax PN Control Panel

STANDARD CONFIGURATION WITH 1 OR 2 FLAME SETTINGS

- 2 Control thermostats;
- 2 Second stage thermostats;
- 2 Minimum thermostats;
- 2 Safety thermostats;
- 2 Thermometers;
- 2 Burner switches;
- 2 Circulator switches;

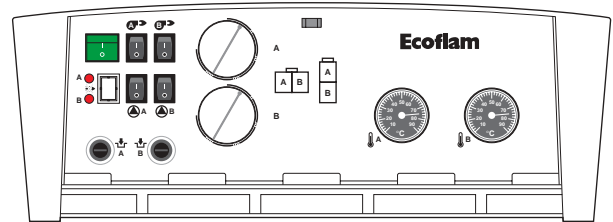

FOR DUOMAX N 140-700
FOR DUOMAX PN 140-2600

ADDITIONAL FUNCTIONS FOR VERSION WITH ELECTRONIC CONTROL

- Equipped with programmable digital regulator to manage the power settings in sequence;
- Possibility of adjusting the temperature and the differential of the sequence;
- Automatic rotation of the burner power stages.

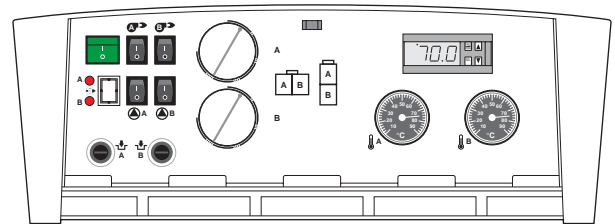

FOR DUOMAX N 140-700
FOR DUOMAX PN 140-2600

ADDITIONAL FUNCTIONS FOR ELECTRONIC VERSION WITH SLIDING TEMPERATURE

- Heating timer programming;
- DHWS timer programming;
- Battery reserve: 2 years;
- Management of 2 burners with two power stages (for a total of four power stages);
- Temperature curve setting compensated by external sensor;
- Heating element circulator control;
- Control of a heating zone with a pump and possibly a mixer valve (an additional sensor is necessary);
- DHWS circulator control;
- Possibility of BMS control with 0-10V control;
- Possibility of MASTER or SLAVE configuration for cascade operation (up to a maximum of 16 power stages) with additional sensor;
- Possibility of a remote control connection;
- Complemented with external sensor.

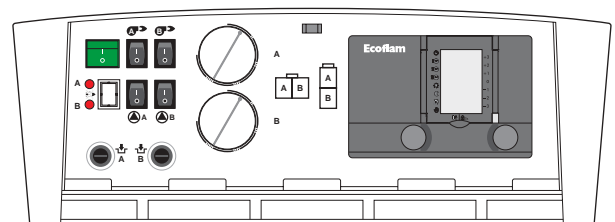

FOR DUOMAX N 140-700
FOR DUOMAX PN 140-2600

Duomax N

140 ÷ 700

**SPACE SAVING STACKED
REVERSE FLAME STEEL
BOILERS COMPLETE WITH
MATCHED BURNERS**



**Output managed automatically and efficiently for
significant reductions in fuel consumption**

Intelligent, powerful and ecological, Duomax N boilers (with independent, sectional furnaces) provide total control over every function and many advantages: less fuel consumption, reduced emissions of pollutants, extremely quiet operation. Technological research and the quality of the materials employed are the strength of the Duomax N units: made to assure truly unique comfort over time and dependable performance that has no rival.

Packaged boiler:

Mechanical: burners and accessories already in the outfit;

Heating: choice of burner and pre-setting according to the power and boiler operation methods;

Electrical: boiler and burner entirely wired together.

Features:

- Space saving stacked boilers;
- Complete with gas/diesel blown-air burners;
- Boiler and burner perfectly matched for power and operation in total safety;
- Very thick steel shell;
- Two pressurized furnaces with flame reversal that are large in size to have a low thermal load and obtain a reduction in the NOx produced by combustion;
- Power delivery on 1 or 2 flame settings for each furnace (for a total of 2 or 4 operating stages) controlled by independent thermostats, with the possibility therefore of managing each furnace autonomously (versions with 2 or 4 flame settings);
- Cylindrical flue pipes equipped with special turbulator;
- Complete with control panel (depending on type of operation);
- Prewired control panel and burners;
- High thermal insulation;
- Stylish casing;
- Reduced dimensions;
- High seasonal efficiency (heating unit in conformity with Italian law 10 dated 9/1/91 and Italian Presidential Decree D.P.R. no.412 dated 26/8/93).



Internal view of combustion chamber



Special high-efficiency steel turbulators

Control panel:

STANDARD VERSION:

For models with 2/4 flame settings.

ELECTRONIC VERSION:

Variable temperature operation, controlling one mixed circuit (mixer valve + pump) management of cascading generators (max 16 power stages).

On request, available also in version:

DUOMAX NS (dismantled boiler only)

Duomax N natural gas features:

Rated supply pressure: 20 mbar;
gas ramps available with rated pressures 40, 100, 300 mbar. For other supply pressures only on request.

When there are special needs to lower the noise levels in the heating plant, an additional silencer is available on request, to be fitted to the burner intake.

DUOMAX N 140 ÷ 700

		140	160	180	200	240	300	400	500	600	700	
Thermal power	max	kcal/h	120.400	137.600	154.800	172.000	206.400	258.000	344.000	430.000	516.000	602.000
		kW	140	160	180	200	240	300	400	500	600	700
	min	kcal/h	60.200	68.800	77.400	43.000	51.600	64.500	86.000	107.500	129.000	150.500
		kW	70	80	90	50	60	75	100	125	150	175
Thermal capacity	max	kcal/h	131.160	149.900	168.620	187.360	224.840	281.040	374.720	468.400	559.040	652.220
		kW	152,6	174,2	196	217,8	261,4	326,8	435,8	544,6	650	758,4
	min	kcal/h	65.580	74.950	84.310	46.840	56.210	70.260	93.680	117.100	139.760	163.055
		kW	76,3	87,1	98	54,5	65,4	81,7	108,9	136,2	162,5	189,6
Nitrogen oxide emissions		ppm	< 55	< 55	< 55	< 55	< 55	< 55	< 55	< 55	< 55	
NOx (0% O ₂) for natural gas		mg/kWh	< 97	< 97	< 97	< 97	< 97	< 97	< 97	< 97	< 97	
Nitrogen oxide emissions		ppm	< 100	< 100	< 100	< 100	< 100	< 100	< 100	< 100	< 100	
NOx (0% O ₂) for diesel		mg/kWh	< 180	< 180	< 180	< 180	< 180	< 180	< 180	< 180	< 180	
Boiler max operating pressure		bar	6	6	6	6	6	6	6	6	6	
Capacity		l	2x105	2x105	2x123	2x123	2x123	2x172	2x172	2x220	2x300	2x356
Losses of head on water side (1)		mbar	9	10	10	12	13	14	15	15	16	18
Combustion chamber backpressure		mbar	0,8	1	1	1	1,1	1,2	1,9	2	2	2,9
Weight		kg	410	410	490	490	490	660	660	820	900	1030

Overall dimensions

		140	160	180	200	240	300	400	500	600	700	
Dimensions mm	A	700	700	700	700	700	750	750	750	850	850	
	A1	750	750	750	750	750	800	800	800	900	900	
	B	630	630	755	755	755	1000	1000	1250	1250	1500	
	B1	895	895	1020	1020	1020	1267	1267	1517	1517	1769	
	B2	1000	1000	1120	1120	1120	1365	1365	1615	1615	1865	
	C-D	415	415	415	415	415	440	440	440	490	490	
	C1-D1	1245	1245	1245	1245	1245	1320	1320	1320	1470	1470	
	E	270	270	270	270	270	295	295	295	345	345	
	F	780	780	780	780	780	830	830	830	930	930	
	G	1610	1610	1610	1610	1610	1710	1710	1710	1910	1910	
	H	1693	1693	1693	1693	1693	1793	1793	1793	1993	1993	
	Q (2)	204	204	204	204	276	276	276	390	555	555	
	øc	200	200	200	200	200	250	250	250	250	250	
	Couplers ND / in	N1/N2	50	50	50	50	50	50	50	50	65	65
		N4	1"	1"	1"	1"	1"	1"	1"	1"	1"	1"
N6		1/2"	1/2"	1/2"	1/2"	1/2"	1/2"	1/2"	1/2"	1/2"	1/2"	

(1) Head losses referring to a temperature jump of 12°C;

(2) For gas burners, the depth Q does not include the gas ramp (this distance refers to ECOFLAM burners only)

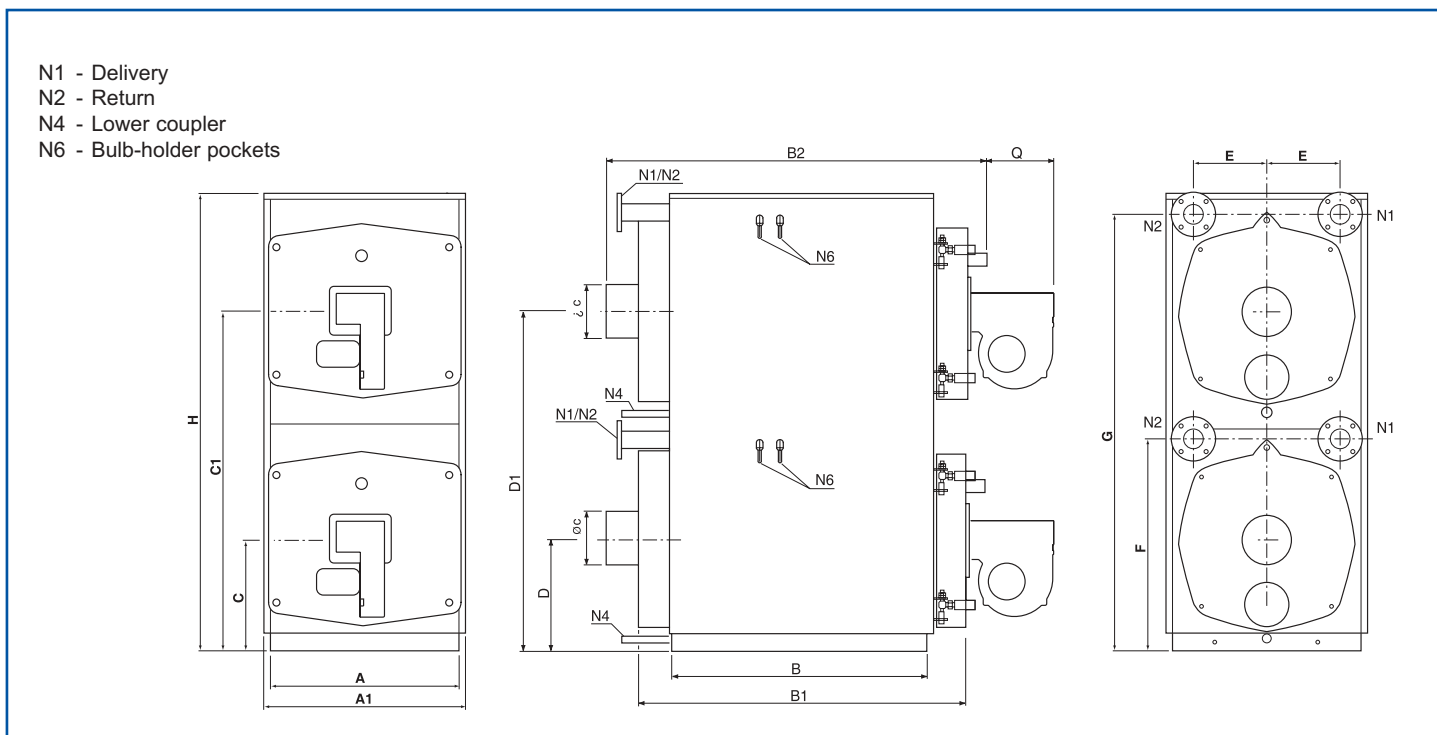

Duomax PN

140 ÷ 600



SPACE SAVING STACKED REVERSE FLAME STEEL BOILERS COMPLETE WITH MATCHED BURNERS

Output managed automatically and efficiently for significant reductions in fuel consumption

The ECOFLAM research laboratories have conceived the innovative **DUOMAX PN** boilers, designed according to the principle of splitting the power that can be delivered to the system.

Intelligent, powerful and ecological, Duomax PN units (with independent, sectional furnaces) provide total control over every function and many advantages: less fuel consumption, reduced emissions of pollutants, extremely quiet operation. Technological research and the quality of the materials employed are the strength of the Duomax PN units: made to assure truly unique comfort over time and dependable performance that has no rival.

Packaged boiler:

Mechanical: burners and accessories already in the outfit;

Heating: choice of burner and pre-setting according to the power and boiler operation methods;

Electrical: boiler and burner entirely wired together.

Features:

- Space saving stacked boiler;
- Complete with gas/diesel blown-air burners;
- Boiler and burner perfectly matched for power and operation in total safety;
- Very thick steel shell;
- Two pressurized furnace with flame reversal;
- Power delivery on 1 or 2 flame settings for each furnace (for a total of 2 or 4 operating stages) controlled by independent thermostats, with the possibility therefore of managing each furnace autonomously (versions with 2 or 4 flame settings);
- Cylindrical flue pipes equipped with special turbulator;
- Complete with control panel (depending on type of operation);
- Prewired control panel and burners;
- High thermal insulation;
- Stylish casing;
- Reduced dimensions;
- High seasonal efficiency (heating unit in conformity with Italian law 10 dated 9/1/91 and Italian Presidential Decree D.P.R. no.412 dated 26/8/93).

When there are special needs to lower the noise levels in the heating plant, an additional silencer is available on request, to be fitted to the burner intake.

The Duomax PN version is fitted as standard with a removable sound deadening casing.

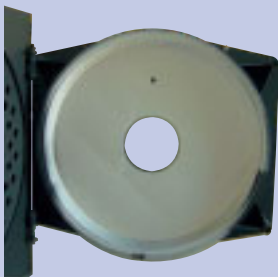

Internal door lined with ceramic fibre for high insulation

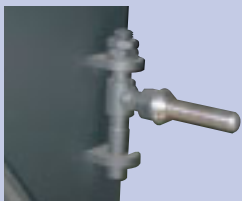

Special closing: for better maintenance the door can be opened either to the right or to the left.

Control panel:

STANDARD VERSION:

For models with 2/4 flame settings.

ELECTRONIC VERSION:

Variable temperature operation, controlling one mixed circuit (mixer valve + pump) management of cascading generators (max 16 power stages).

On request, available also in version:

DUOMAX PNS (dismantled boiler only)

Duomax PN natural gas features:

Rated supply pressure: 20 mbar;
gas ramps available with rated pressures 40, 100, 300 mbar. For other supply pressures only on request.

DUOMAX PN 140 ÷ 600

			140	160	180	200	240	300	400	500	600
Thermal power	max	kcal/h	120.400	137.600	154.800	172.000	206.400	258.000	344.000	430.000	516.000
		kW	140	160	180	200	240	300	400	500	600
	min	kcal/h	60.200	68.800	77.400	43.000	51.600	64.500	86.000	107.500	129.000
		kW	70	80	90	50	60	75	100	125	150
Thermal capacity	max	kcal/h	131.160	149.900	168.620	187.360	224.840	281.040	374.720	468.400	559.040
		kW	152,6	174,2	196	217,8	261,4	326,8	435,8	544,6	650
	min	kcal/h	65.580	74.950	84.310	46.840	56.210	70.260	93.680	117.100	139.760
		kW	76,3	87,1	98	54,5	65,4	81,7	108,9	136,2	162,5
Nitrogen oxide emissions		ppm	< 55	< 55	< 55	< 55	< 55	< 55	< 55	< 55	< 55
NOx (0% O ₂) for natural gas		mg/kWh	< 97	< 97	< 97	< 97	< 97	< 97	< 97	< 97	< 97
Nitrogen oxide emissions		ppm	< 100	< 100	< 100	< 100	< 100	< 100	< 100	< 100	< 100
NOx (0% O ₂) for diesel		mg/kWh	< 180	< 180	< 180	< 180	< 180	< 180	< 180	< 180	< 180
Boiler max operating pressure		bar	6	6	6	6	6	6	6	6	6
Capacity		l	105 x 2	105 x 2	123 x 2	123 x 2	123 x 2	172 x 2	172 x 2	220 x 2	300 x 2
Losses of head on water side (1)		mbar	9	10	11	12	13	14	15	16	16
Combustion chamber backpressure		mbar	0,8	1	0,8	1	1,1	1,2	1,9	2	2
Weight		kg	200 x 2	200 x 2	240 x 2	240 x 2	240 x 2	320 x 2	320 x 2	400 x 2	440 x 2

Overall dimensions

		140	160	180	200	240	300	400	500	600
Dimensions mm		A	1465	1465	1465	1465	1565	1565	1565	1765
		A1	1515	1515	1515	1515	1615	1615	1615	1815
		B	630	630	755	755	755	1000	1000	1250
		B1	895	895	1020	1020	1020	1267	1267	1517
		C	1000	1000	1120	1120	1120	1365	1365	1615
		D	415	415	415	415	415	440	440	490
		E	415	415	415	415	440	440	440	490
		H	855	855	855	855	855	905	905	1005
		L	240	240	265	265	265	475	475	725
		M	415	415	484	484	484	484	484	484
		P	56	56	56	56	56	56	56	56
		Q (2)	204	204	204	204	276	276	276	390
		øc	200	200	200	200	200	250	250	250
Couplers ND / in		N1/N2	50	50	50	50	50	50	50	65
		N3	1"	1"	1"	1"	1"	1"	1"	1"
		N4	1"	1"	1"	1"	1"	1"	1"	1"
		N5	(3)	(3)	(3)	(3)	(3)	(3)	(3)	(3)
		N6	1/2"	1/2"	1/2"	1/2"	1/2"	1/2"	1/2"	1/2"

Contd....

(1) Head losses referring to a temperature jump of 12°C;

(2) For gas burners, the depth Q does not include the gas ramp (this distance refers to ECOFLAM burners only);

(3) Coupler not included.

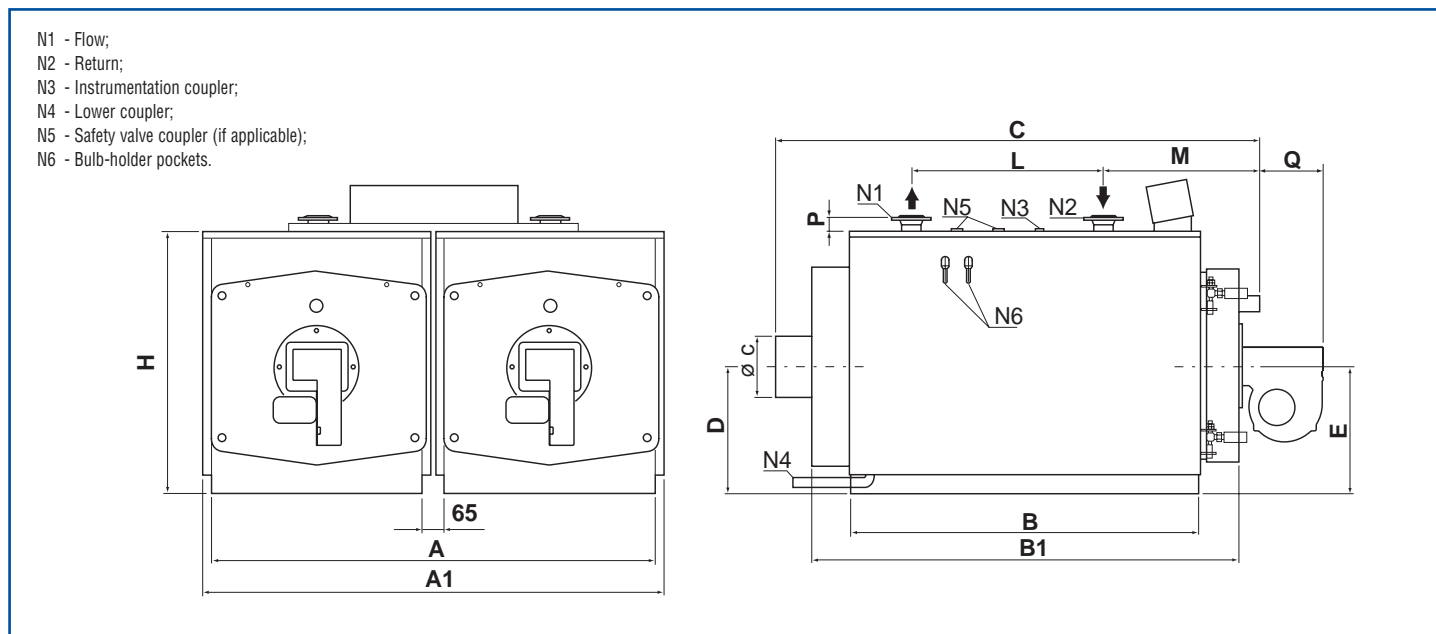

Duomax PN

700 ÷ 2600

**SPACE SAVING STACKED
REVERSE FLAME
STEEL BOILERS
COMPLETE WITH
MATCHED BURNERS**



High-density glass wool thermal insulation, 80 mm thick.

Control panel:

STANDARD VERSION:
For models with 2/4 flame settings.

ELECTRONIC VERSION:

Sliding temperature operation, controlling one mixed circuit (mixer valve + pump) management of cascading generators (max 16 power stages).

On request, available also in version:
DUOMAX PNS (dismantled boiler only)

Duomax PN natural gas features:

Rated supply pressure: 20 mbar;
gas ramps available with rated pressures 40, 100, 300 mbar. For other supply pressures only on request.

Output managed automatically and efficiently for significant reductions in fuel consumption

Intelligent, powerful and ecological, Duomax PN boilers (with independent, sectional furnaces) provide total control over every function and many advantages: less fuel consumption, reduced emissions of pollutants, extremely quiet operation. Technological research and the quality of the materials employed are the strength of the Duomax PN units: made to assure truly unique comfort over time and dependable performance that has no rival.

Packaged boiler:

Mechanical: burners and accessories already in the outfit.

Heating: choice of burner and pre-setting according to the power and boiler operation methods.

Electrical: boiler and burner entirely wired together.

- Space saving stacked boilers;
- Complete with gas/diesel blown-air burners;
- Boiler and burner perfectly matched for power and operation in total safety;
- Very thick steel shell;
- Two pressurized furnace with flame reversal;
- Power delivery on 1 or 2 flame settings for each furnace (for a total of 2 or 4 operating stages) controlled by independent thermostats, with the possibility therefore of managing each furnace autonomously (versions with 2 or 4 flame settings);
- Cylindrical flue pipes equipped with special turbulator;
- Complete with control panel (depending on type of operation);
- Prewired control panel and burners;
- High thermal insulation;
- Stylish casing;
- Reduced dimensions;
- High seasonal efficiency (heating unit in conformity with Italian law 10 dated 9/1/91 and Italian Presidential Decree D.P.R. no.412 dated 26/8/93).

When there are special needs to lower the noise levels in the heating plant, an additional silencer is available on request, to be fitted to the burner intake.

The Duomax PN version is fitted as standard with a removable sound deadening casing.

DUOMAX PN 700 ÷ 2600

			700	840	1020	1260	1500	1740	1940	2060	2400	2600
Thermal power	max	kcal/h	602.000	722.400	877.200	1.083.600	1.290.000	1.496.400	1.668.400	1.771.600	2.064.000	2.236.000
		kW	700	840	1020	1260	1500	1740	1940	2060	2400	2600
	min	kcal/h	150.500	180.600	219.300	270.900	322.500	374.100	417.100	442.900	516.000	559.000
		kW	175	210	255	315	375	435	485	515	600	650
Thermal capacity	max	kcal/h	652.220	782.660	950.380	1.174.000	1.397.620	1.621.240	1.807.580	1.919.400	2.236.180	2.422.540
		kW	758,4	910	1105	1365,2	1625,2	1885,2	2101,8	2231,8	2600,2	2817
	min	kcal/h	163.055	195.665	237.595	293.500	349.405	405.310	451.895	479.850	559.045	605.635
		kW	189,6	227,5	276,3	341,3	406,3	471,3	525,5	558	650,1	704,2
Nitrogen oxide emissions		ppm	< 55	< 55	< 55	< 55	< 55	< 55	< 55	< 55	< 55	< 55
NOx (0% O ₂) for natural gas		mg/kWh	< 97	< 97	< 97	< 97	< 97	< 97	< 97	< 97	< 97	< 97
Nitrogen oxide emissions		ppm	< 100	< 100	< 100	< 100	< 100	< 100	< 100	< 100	< 100	< 100
NOx (0% O ₂) for diesel		mg/kWh	< 180	< 180	< 180	< 180	< 180	< 180	< 180	< 180	< 180	< 180
Boiler max operating pressure		bar	6	6	6	6	6	6	6	6	6	6
Capacity		l	356 x 2	360 x 2	540 x 2	645 x 2	855 x 2	855 x 2	950 x 2	1200 x 2	1200 x 2	1200 x 2
Losses of head on water side (1)		mbar	18	25	22	27	25	25	39	26	30	30
Combustion chamber backpressure		mbar	2,9	4,1	4,2	6,4	5,2	7,2	5,2	4	5,5	6,5
Weight		kg	500 x 2	540 x 2	800 x 2	900 x 2	1140 x 2	1140 x 2	1340 x 2	1760 x 2	1760 x 2	1760 x 2

Overall dimensions		700	840	1020	1260	1500	1740	1940	2060	2400	2600
Dimensions mm											
	A	1765	1845	2285	2285	2545	2545	2545	2845	2845	2845
	A1	1815	1895	2335	2335	2595	2595	2595	2895	2895	2895
	B	1500	1502	1502	1792	1753	1753	2003	2003	2003	2003
	B1	1769	1791	1838	2127	2143	2143	2393	2374	2374	2374
	C	1865	1875	1950	2240	2250	2250	2500	2500	2500	2500
	D	490	500	610	610	675	675	675	750	750	750
	E	490	500	610	610	675	675	675	750	750	750
	H	1005	1015	1205	1205	1335	1335	1335	1485	1485	1485
	L	980	850	850	1150	1100	1100	1200	1200	1200	1200
	M	484	600	660	660	710	710	710	710	710	710
	P	56	80	80	80	82	82	82	83	83	83
	Q (2)	555	555	555	555	555	555	555	555	660	660
	∅c	250	250	300	300	350	350	350	400	400	400
Couplers ND / in	N1/N2	65	80	80	80	100	100	100	125	125	125
	N3	1"	1"	1"	1"	1"	1"	1"	1"	1"	1"
	N4	1"	1"	1" 1/4	1" 1/4	1" 1/4	1" 1/4	1" 1/4	1" 1/4	1" 1/4	1" 1/4
	N5	(3)	1" 1/4(4)	1" 1/4	1" 1/4	1" 1/2	1" 1/2	1" 1/2	1" 1/2	1" 1/2	1" 1/2
	N6	1/2"	1/2"	1/2"	1/2"	1/2"	1/2"	1/2"	1/2"	1/2"	1/2"

- (1) Head losses referring to a temperature jump of 12°C;
 (2) For gas burners, the depth Q does not include the gas ramp (this distance refers to ECOFLAM burners only);
 (3) Coupler not included,
 (4) A single coupler N5

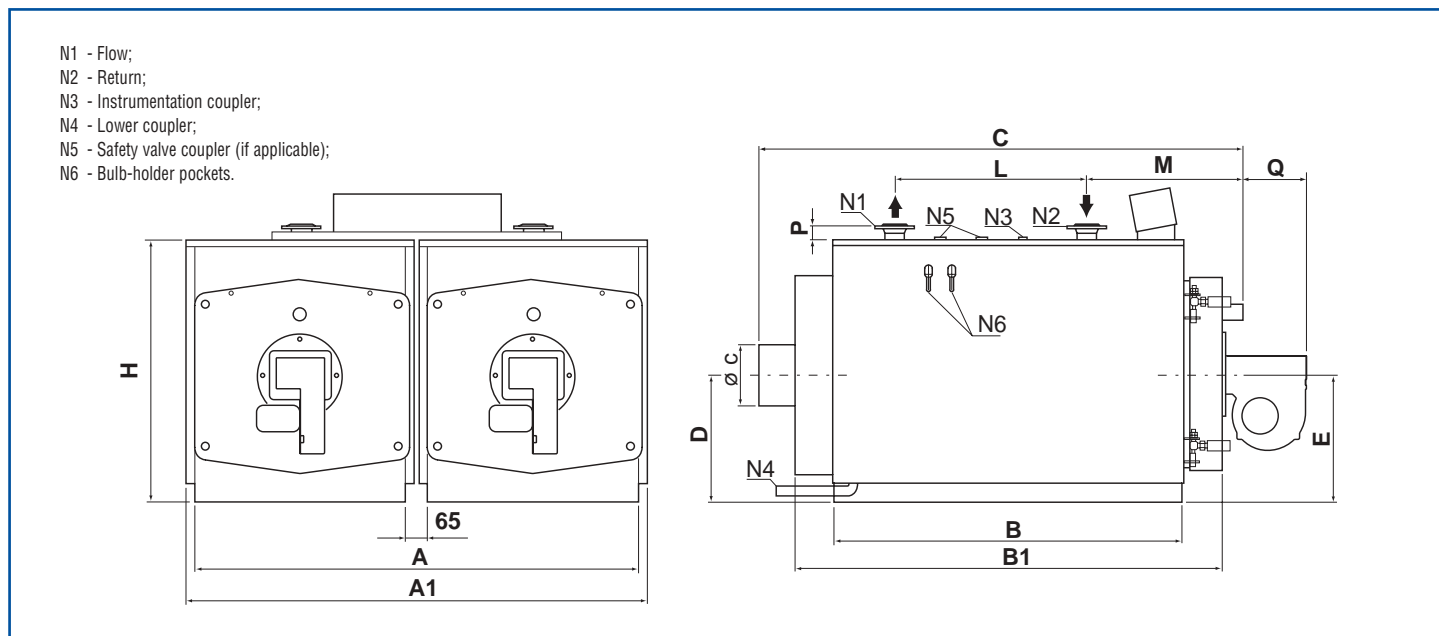

Ecomax NC

REVERSE FLAME STEEL BOILER

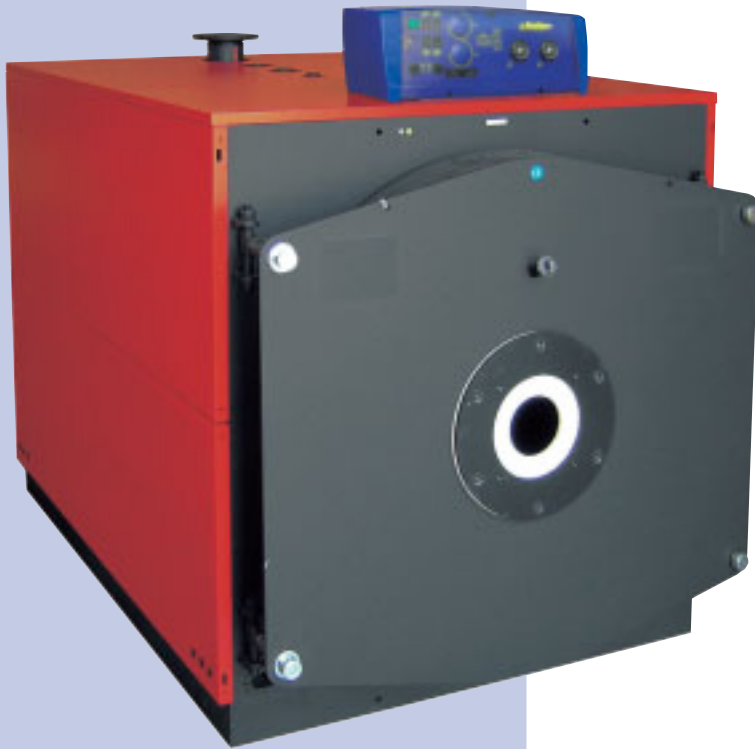

Features:

- Very thick steel shell;
- Pressurized furnace with flame reversal;
- Cylindrical flue pipes equipped with special turbulator;
- Complete with control panel;
- High thermal insulation;
- Stylish casing;
- Can work with either liquid or gas fuel;
- High seasonal efficiency (heating unit in conformity with Italian law 10 dated 9/1/91 and Italian Presidential Decree D.P.R. no.412 dated 26/8/93).

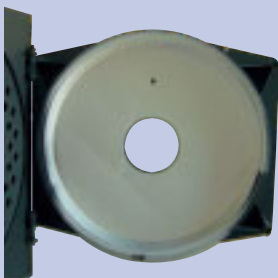

Internal door lined with ceramic fibre for high insulation

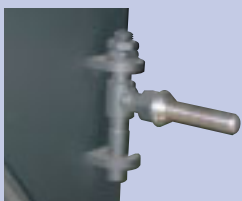

Special closing: for better maintenance the door can be opened either to the right or to the left

ECOMAX NC CONTROL PANEL Configuration with 1 or 2 flame settings

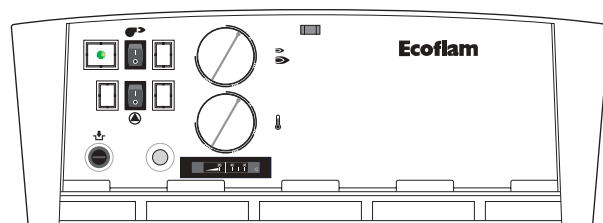

- Control thermostat;
- Second stage thermostat;
- Minimum thermostat;
- Safety thermostat;
- Thermometer;
- Burner switch;
- Circulator switch.

			70	80	90	100	120	150	200	250
Thermal power	max	kcal/h	60.200	68.800	77.400	86.000	103.200	129.000	172.000	215.000
		kW	70	80	90	100	120	150	200	250
	min	kcal/h	30.100	34.400	38.700	43.000	51.600	64.500	86.000	107.500
		kW	35	40	45	50	60	75	100	125
Furnace pressure	mbar		0,8	1	0,8	1	1,1	1,2	1,9	2
Dimensions (mm)	L		750	750	750	750	750	800	800	800
	H		855	855	855	855	855	905	905	905
	P		895	895	1.020	1.020	1.020	1.267	1.267	1.517
	ø D		200	200	200	200	200	250	250	250

			300	350	420	510	630	750	870	970	1030
Thermal power	max	kcal/h	258.000	301.000	361.200	438.600	541.800	645.000	748.200	834.200	885.800
		kW	300	350	420	510	630	750	870	970	1.030
	min	kcal/h	129.000	150.500	180.600	219.300	270.900	322.500	374.100	417.100	442.900
		kW	150	175	210	255	315	375	435	485	515
Furnace pressure	mbar		2	2,9	4,1	4,2	6,4	5,2	7,2	5,2	4
Dimensions (mm)	L		900	900	940	1.160	1.160	1.290	1.290	1.290	1.440
	H		1.005	1.005	1.015	1.205	1.205	1.335	1.335	1.335	1.485
	P		1.519	1.769	1.791	1.838	2.127	2.143	2.143	2.393	2.374
	ø D		250	250	250	300	300	350	350	350	400

			1200	1300	1400	1600	1800	2000	2400	3000	3500
Thermal power	max	kcal/h	1.032.000	1.118.000	1.204.000	1.376.000	1.548.000	1.720.000	2.064.000	2.580.000	3.010.000
		kW	1.200	1.300	1.400	1.600	1.800	2.000	2.400	3.000	3.500
	min	kcal/h	516.000	559.000	602.000	688.000	774.000	860.000	1.032.000	1.290.000	1.505.000
		kW	600	650	700	800	900	1.000	1.200	1.500	1.750
Furnace pressure	mbar		5,5	6,5	6	6,5	5,5	6	7,5	8	8,5
Dimensions (mm)	L		1.440	1.440	1.470	1.470	1.470	1.600	1.600	1.870	1.870
	H		1.485	1.485	1.630	1.630	1.630	1.760	1.760	2.030	2.030
	P		2.374	2.374	2.793	2.793	3.003	3.132	3.392	3.392	3.847
	ø D		400	400	400	400	400	500	500	550	550

The Ecomax NC 1400-3500 models feature a preassembled, stylish, rounded casing made of embossed aluminium.

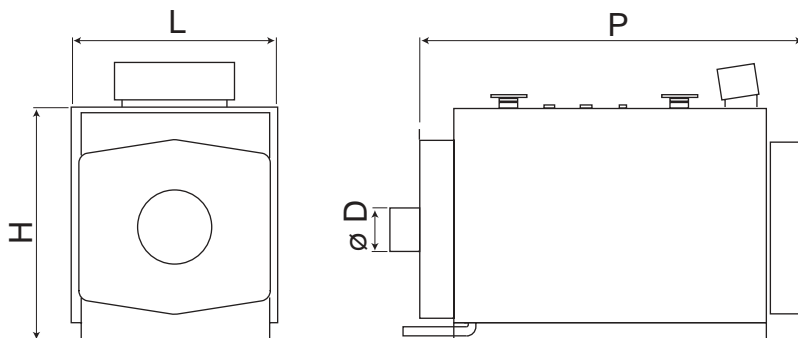

Ecomax NCS

Dismantled

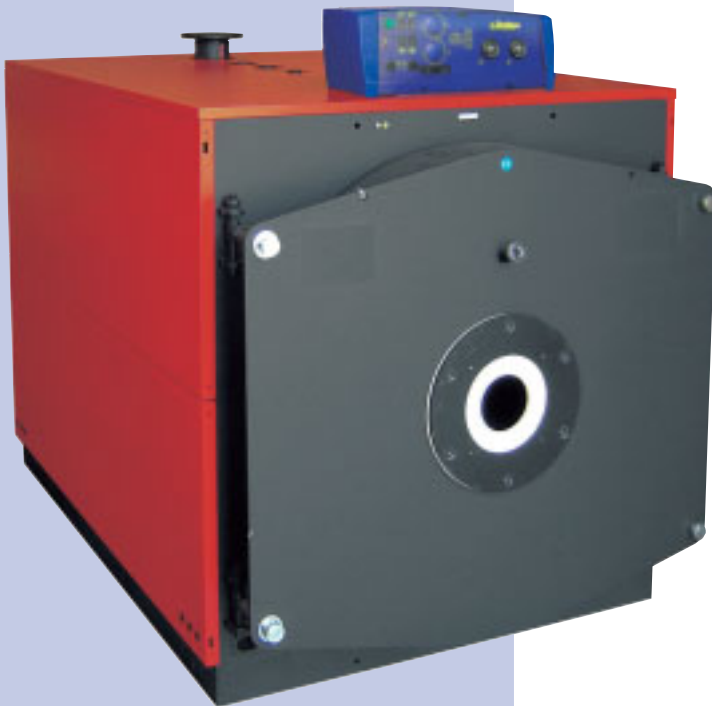

REVERSE FLAME STEEL BOILER

The Ecomax NCS heat generator is supplied dismantled in order to be assembled in the heating plant during installation if it was not possible to insert the boiler already assembled.

The technical and mechanical specifications of the ECOMAX NC series are unchanged.

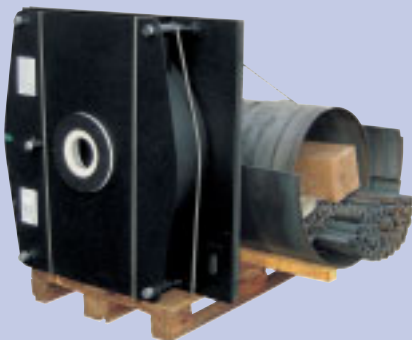

Features:

- Very thick steel shell;
- Pressurized furnace with flame reversal;
- Cylindrical flue pipes equipped with special turbulator;
- Complemented with control panel;
- High thermal insulation;
- Stylish casing;
- Can work with either liquid or gas fuel;
- High seasonal efficiency (heating unit in conformity with Italian law 10 dated 9/1/91 and Italian Presidential Decree D.P.R. no.412 dated 26/8/93).



			90	100	120	150	200	250	300	350
Thermal power	max	kcal/h	86.000	86.000	103.200	129.000	172.000	215.000	258.000	301.000
		kW	100	100	120	150	200	250	300	350
	min	kcal/h	43.000	43.000	51.600	64.500	86.000	107.500	129.000	150.500
		kW	50	50	60	75	100	125	150	175
Furnace pressure	mbar		1	1	1,1	1,2	1,9	2	2	2,9
Dimensions (mm)	L		750	750	750	800	800	800	900	900
	H		855	855	855	905	905	905	1.005	1.005
	P		1.020	1.020	1.020	1.267	1.267	1.517	1.519	1.769
	ø D		200	200	200	250	250	250	250	250

			420	510	630	750	870	970	1030	1200	1300
Thermal power	max	kcal/h	361.200	438.600	541.800	645.000	748.200	834.200	885.800	1.032.000	1.118.000
		kW	420	510	630	750	870	970	1.030	1.200	1.300
	min	kcal/h	180.600	219.300	270.900	322.500	374.100	417.100	442.900	516.000	559.000
		kW	210	255	315	375	435	485	515	600	650
Furnace pressure	mbar		4,1	4,2	6,4	5,2	7,2	5,2	4	5,5	6,5
Dimensions (mm)	L		940	1.160	1.160	1.290	1.290	1.290	1.440	1.440	1.440
	H		1.015	1.205	1.205	1.335	1.335	1.335	1.485	1.485	1.485
	P		1.791	1.838	2.127	2.143	2.143	2.393	2.374	2.374	2.374
	ø D		250	300	300	350	350	350	400	400	400

Ecomax NCS 1400-3500 on request with the possibility of customization

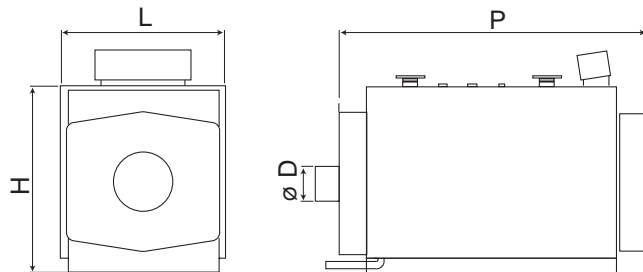

WEIGHTS AND DIMENSIONS OF THE BULKIEST PARTS

Mod. ECOMAX	FURNACE		DOOR	
	Weight	mm	Weight	mm
90	29	ø 400 x 740	50	700 x 630
100	29	ø 400 x 740	50	700 x 630
120	29	ø 400 x 740	50	700 x 630
150	54	ø 450 x 988	65	750 x 680
200	54	ø 450 x 988	65	750 x 680
250	73	ø 500 x 1240	90	850 x 778
300	73	ø 500 x 1240	90	850 x 778
350	88	ø 500 x 1490	90	850 x 778
420	115	ø 545 x 1490	110	890 x 807
510	161	ø 645 x 1500	180	1100 x 984
630	161	ø 645 x 1500	180	1100 x 984
750	227	ø 690 x 1800	210	1240 x 1130
870	227	ø 690 x 1800	210	1240 x 1130
970	257	ø 690 x 2050	210	1240 x 1270
1030	316	ø 790 x 2065	235	1390 x 1270
1200	316	ø 790 x 2065	235	1390 x 1270
1300	316	ø 790 x 2065	235	1390 x 1270

